

Architectural Engineering Senior Thesis



Science & Technology Center · Chestnut Hill Academy - Philadelphia, PA
David Klug · Mechanical Option · Advisor - Dr. Freihaut
April 15th, 2009

Presentation Outline

- **Background Information**

- i. Project Summary
- ii. Existing Conditions

- **Breadth Topics**

- i. Acoustics
- ii. Daylighting

- **Depth Topics**

- i. Dedicated Outdoor Air
- ii. Active Chilled Beams
- iii. Thermal Energy Storage

- **Conclusions**

Existing Conditions

CHESTNUT HILL ACADEMY

- 9. Main Entrance: Wissahickon Inn
- 10. Jordan Lower School Entrance
- 11. Middle School Entrance
- 12. Upper School Entrance



- ≈30,000 SF
- \$9.6 Million
- Krieger & Associates
- Bruce E. Brooks & Associates

1. Business Office
2. Lower School Entrance
3. Middle/Upper School Entrance
4. Special Events Entrance
5. Field House
6. Playing Fields
7. Tennis Courts
8. Smilow House (Head of School's Home)

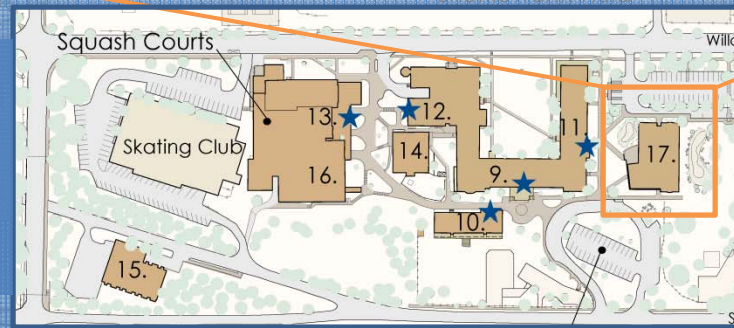

Existing Conditions

Original HVAC Design

- VAV System
 - 57.1 ton air chilled scroll chiller
 - AHU-1 -> 6,300 CFM
 - AHU-2 -> 8,000 CFM

Energy Use

Component	Site Energy		Source Energy	
	(kBTU)	(kBTU/ft ²)	(kBTU)	(kBTU/ft ²)
Total	2,538,758	111.584	7,287,498	344.036

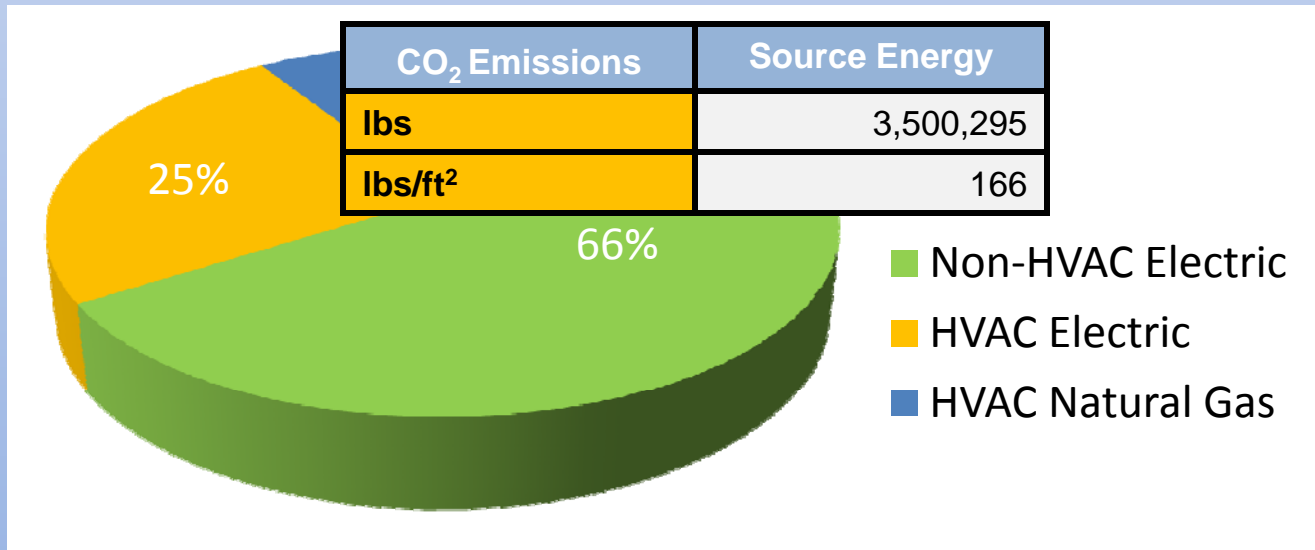

Existing Conditions

Equipment Costs

	Total Cost (\$)	Cost (\$/ft ²)
Fire Protection	90,300	3.97
HVAC	1,196,700	52.57
Total	1,287,000	56.53

Operating Costs

	Annual Cost (\$/yr)	Annual Cost (\$/ft ²)
HVAC Components		
Sub-Total	16,712	0.735
Non-HVAC Components		
Sub-Total	36,156	1.589
Total	52,868	2.324

Acoustical Breadth

- Reverberation Times

	T ₆₀ @ 125	T ₆₀ @ 250	T ₆₀ @ 500	T ₆₀ @ 1000	T ₆₀ @ 2000	T ₆₀ @ 4000
Lobby	0.460	0.464	0.556	0.509	0.423	0.436
Room 107	0.419	0.457	0.579	0.543	0.444	0.472
Room 109	0.415	0.459	0.584	0.536	0.439	0.469
Room 111	0.448	0.474	0.600	0.559	0.453	0.484
Room 115	0.415	0.455	0.575	0.530	0.433	0.463
Room 203	0.304	0.390	0.502	0.445	0.364	0.387
Room 204	0.374	0.417	0.471	0.410	0.367	0.386
Room 206	0.451	0.471	0.591	0.543	0.447	0.481
Room 208	0.453	0.470	0.588	0.541	0.446	0.480
Room 211	0.466	0.471	0.584	0.541	0.448	0.483
1st Floor Corridor	0.596	0.536	0.675	0.622	0.506	0.552
2nd Floor Corridor	0.628	0.553	0.694	0.630	0.513	0.563

Acoustical Breadth

- STC Ratings

	<u>STC Rating</u>
Exterior Walls	
Masonry	58
Stucco	57
Glass	34
Windows	34
Interior Partitions	
Hallway	50
Classrooms	44
Robotics Workshop	44
Doors	27

- Exterior Sounds

- i. Inn Building
- ii. Track and Field
- iii. Willow Grove Avenue

Daylight Breadth

- Daylight System
 - Dual Room miniZ™
 - Occupancy Sensors
- Re-Design
 - Orientation
 - Light Shelves

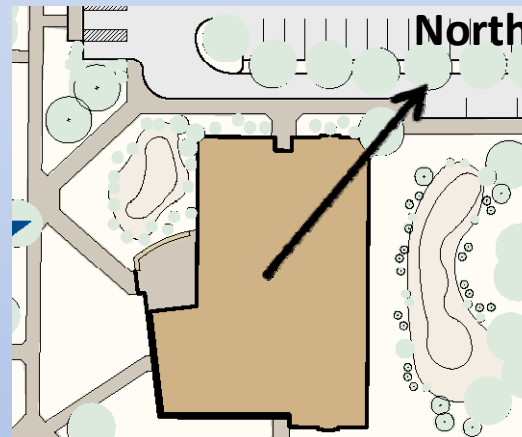

Alternative HVAC Design

- Dedicated Outdoor Air
- Active Chilled Beams
 - Humidity Control
 - Energy Consumption
- Thermal Energy Storage

Component	Site Energy		Source Energy	
	(kBTU)	(kBTU/ft ²)	(kBTU)	(kBTU/ft ²)
			6,494,375	317.15

	CO ₂ Emissions	Source Energy
Peak Cooling Load		
Cooling Requirement		
	lbs	3,119,346
	lbs/ft ²	152

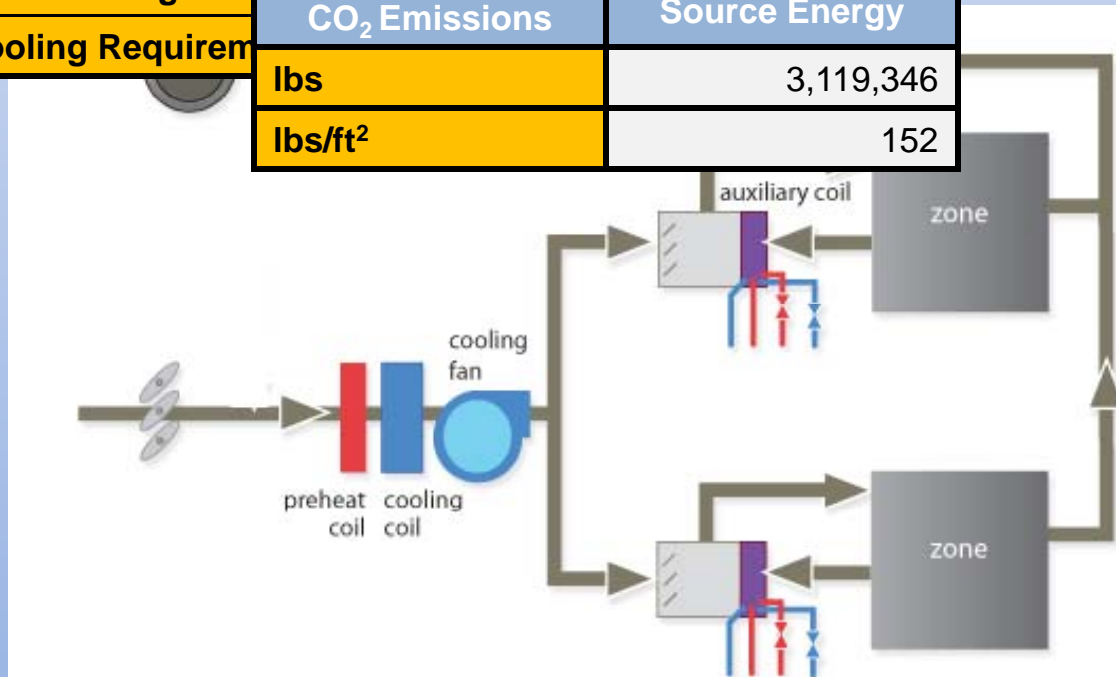

Alternative HVAC Design

- Equipment Costs

System Costs	Cost (\$)
Original Cost	1,287,000
Subtracted Equipment	760,500
New Equipment	706,224
Total	1,232,724

- Operating Costs

Operating Cost	Cost (\$/year)
Original Operating Cost	52,868
ACB Operating Cost	+19,730
TES Operating Cost	-5,533
Total	67,065

Conclusions

- HVAC Re-Design
 - i. More energy
 - ii. Higher operating costs
- Daylighting
 - i. Justified
- Acoustics
 - i. Reverberation times good
 - ii. STC ratings good
 - iii. NC ratings good